

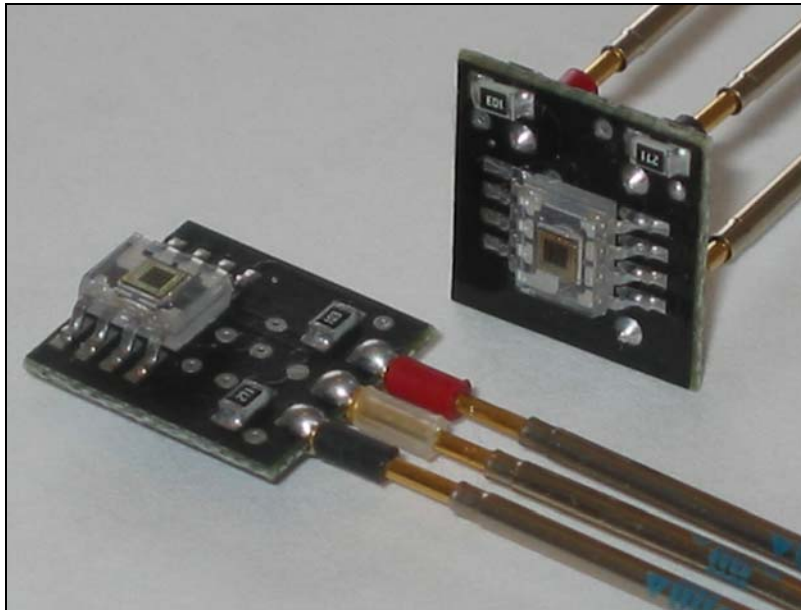

TEST COACH
CORPORATION

Smart FINN[®]

Manual of Specifications



This file documents the Test Coach Corp. Smart FINN[®] color sensor product.

Materials and Information Provided for the Smart FINN[®]

1. HP parts description library file (separate file*).
2. Smart FINN tool (separate files*).
3. Instructions for development, integration, adjustment, and fixture construction.

Separate files are available online @

http://www.testcoach.com/finnProducts/FinnGeneral/finn_downloads.htm

Table of Contents

Table of Contents	2
1. Principal of Operation	3
2. Method of Operation	3
3. Features	3
4. Applications	3
5. Properties	4
5.1. <i>Dimensions</i>	4
5.2. <i>Power Source</i>	4
5.3. <i>Sensor</i>	4
5.4. <i>Controller</i>	4
5.5. <i>Table of Typical Measurements</i>	4
6. Understanding Measurements	5
6.1 <i>Voltage and Brightness</i>	5
6.2 <i>Frequency and Color</i>	5
6.3 <i>Recommended Timing and Test Flows</i>	6
7. Part Numbers and Descriptions	6
8. Sources of Error	7
8.1 <i>Wiring</i>	7
8.2 <i>Outside light and adjacent LED's</i>	7
8.3 <i>Distance</i>	7
8.4 <i>V_{dd} other than 5V</i>	7
8.5 <i>Saturation</i>	7
8.6 <i>Temperature</i>	7
9. Fixture Considerations	8
9.1 <i>Wiring and Sockets</i>	8
9.2 <i>Distances</i>	8
9.3 <i>Light pipe and light conduit</i>	8
10. Absolute Maximum Ratings	9
11. Recommended Operating Conditions	9
12. 5-V DC Electrical Characteristics	9
13. 3-V DC Electrical Characteristics	9
14. Other Application Notes	10
14.1 <i>Low Pass Filter for DC Measurements</i>	10
14.2 <i>Passive Measurements for Wiring Verification</i>	10
15. Drawing – TC08SF-R, Smart FINN[®] Right Angle	11
16. Set Height for Right Angle Smart FINN[®]	12
17. Drawing – TC08SF-V, Smart FINN[®] Vertical	13
18. Revision 2.5 – January 1, 2008	14
19. Revision 2.42 – August 1, 2006	14
20. Revision 2.42 – March 17, 2005	15
21. Change to Smart FINN Manual - June 2009	15
22. APPENDIX A	16

Smart FINN®

1. Principal of Operation

The Smart FINN® boasts an all-in-one sensor – four sensors combined into one. Each sensor is designed to detect a certain range of color – blue, red, green or clear. By comparing readings we can get a very accurate measurement of the wavelength of the light hitting the sensor. The key to the design is simplicity. Other than a power and ground connection, the only connection to the sensor is the output. This output indicates both the color and the strength of the LED under test.

2. Method of Operation

The output frequency is directly related to the wavelength (color) of the light. The signal is pulse-width modulated to indicate the intensity of the light. Taking a DC measurement of the signal gives you a measurement of the light intensity.

3. Features

- Full color detection from ultraviolet through infrared
- Wide operating voltage (2.7 Vdc – 5.5 Vdc)
- Standard bed of nails probes used for connections
- Can be powered directly from a digital output
- Color identification determined with one signal
- Intensity reading supplied with one signal
- Right angle mounting is similar to the Agilent TestJet™
- Totally automated, no operator action required
- Significantly faster than operator inspection

4. Applications

- Any test environment when LED color verification is required
- Used across a broad range of industries – automotive, telecommunication, network solutions, medical
- Quality control for most in-line manufacturing environments

5. Properties

5.1. *Dimensions*

0.486 inch x 0.485 inch x 0.176 inch (not including spring probes)

5.2. *Power Source*

Unlike the original FINN®, the Smart FINN® requires a minimal power voltage source, which may vary from 2.7 volts to 5.5 volts, current is typically 8mA@5V. Power is marked with a + (plus) sign on the PCB and red heat-shrink on the probe. Ground is marked with a – (minus) sign on the PCB and black heat-shrink on the probe.

5.3. *Sensor*

Four sensors combined into one specially designed to detect color: Blue, Red, Green and Clear.

5.4. *Controller*

Because this system is microcontroller based, enhancements can be made in software. Look forward to additional application features.

5.5. *Table of Typical Measurements*

TYPICAL MEASUREMENTS @Vdd=5.0				
Color	nm	mcd	kHz	Vdc
Red	635	150	11.7	4.5
Amber	608	10	10.6	2.0
Yellow	585	150	9.1	4.0
Green	565	150	8.5	3.0
Blue	430	x	6.9 **	x
OTHER MEASUREMENTS @Vdd=5.0				
Infrared	Up to 660	x	12.1-12.5	x
Ultraviolet	Down to 380	x	6.25-6.8	x
Fluorescent	multiple	x	4.0	x
White(red dominant)	multiple	x	4.4-6.0	x
White(blue dominant)	multiple	x	3.2-4.0	x
Saturation	n/a	Above 200*	2.02 **	4.8
Dark	n/a	Below 1*	0.998	0.2

*These values are for typical environments (25 degrees Celsius). For additional detail, please refer to the technical discussions later in this document. Please note the voltage output is dependant on the color. The highest voltage is output for red and declines as the wavelength declines.

** With Rev 2.5 these values changed very slightly. Blue kHz reading was 7.0 and is now 6.9. The Saturation reading was 1.996 and is now 2.02 kHz

6. Understanding Measurements

6.1 *Voltage and Brightness*

This sensor is designed to accommodate a wide range of LED's. The sensor has 2 ranges for output brightness. Please note that many factors affect the amount of light from the LED hitting the sensor and the mili-candela (mcd) figures in the examples may be different from the mcd figures of the LED's.

The lower range is for LED's with lower output intensity, typically less than 20mcd. The lower range output is from 0 to Vdd/2, if using Vdd@5Vdc then a 20mcd LED gives an output of 2.5V. The output is not linear so a 10mcd LED would give 2.0Volts DC out. For a more precise correlation of LED strength to output voltage please use the software Smart FINN Tool available on the downloads page at www.testcoachcorp.com. ([link](#)).

The upper range is for LED's with roughly 20-200mcd outputs. The output of the range starts at Vdd/2. The increase in voltage per mcd is 1/8 the increase on the lower scale. So, for a 30mcd LED the first 20mcd accounts for 2.5volts in the output and the next 10mcd accounts for only 0.75Volts DC.

The sensor has slightly different responses to different wavelengths. Red has the highest output response. The green response is about 80% of the red and the pure blue response is about 60% of the red response.

6.2 *Frequency and Color*

The Smart Finn[®] uses a microprocessor with a built-in oscillator circuit. All output frequencies and pulse widths are dependant on the frequency of the oscillator circuit. This oscillator is trimmed to 3.2 MHz with a Vdd of 5Volts DC and 25 degrees Celsius. The accuracy under these conditions is within 0.5%. The microprocessor creates the frequency output by increasing the period of the repeating signal. The period is increased in increments of 312.5nsec. For a typical green the period is $376 \times 312.5\text{nsec} = 117.5\mu\text{sec}$ (8.511khz). For typical yellow the period is $350 \times 312.5\text{nsec} = 109.4\mu\text{sec}$ (9.142khz). There are 26 other possible frequencies between green and yellow to detect minute differences in color. There are 74 possible frequencies between yellow and red.

The frequency will vary slightly due to temperature and supply voltage. See sections 8.4 and 8.6 in the manual for options to increase accuracy. The frequency variation has no affect on the voltage readings used for brightness tests.

The Smart Finn[®] will identify if the light source contains significant amounts of all three primary colors (red, green, and blue) and treat it as white light. The response to white light is a variable frequency between 3.1khz and 6.2khz and will be closer to 3.1khz for white light with a majority blue component and closer to 6.2khz if the major component is red. Also, the brightness of the light is proportional to the dc average of the output signal.

Saturation (2.02khz) will occur if the light is too bright. The Dark reading (998.4hz) is given if the light is too dim to be measured.

6.3 Recommended Timing and Test Flows

- A) Turn on LED:
 - Power up sensor:
 - Delay Wait Time for reading
 - Measure Voltage for Intensity
 - Measure Frequency for Color

- B) Power up sensor:
 - Turn on LED:
 - Delay Wait Time for reading
 - Measure Voltage for Intensity
 - Measure Frequency for Color

<u>Good voltage reading</u>	<u>Worst case wait time*</u>
Less than 0.5	400msec
0.5-1.5	200msec
1.5-2.5	100msec
2.5-3.5	50msec
above 3.5	25msec

*If the sensor is powered up before the LED the first reading cycle may have samples from the unlit time period and thus a second sampling period is needed. If using Test Flow A, then the wait can be reduced to half the worst case. Also wait times can be reduced if the voltage is measured before the frequency.

7. **Part Numbers and Descriptions**

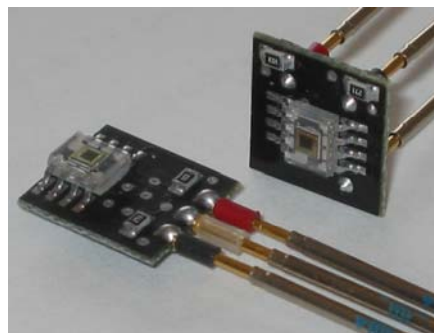

<u>Part Numbers</u>	<u>Obsolete Part Numbers</u>	<u>Description</u>
TC08SF-R	TC03SF-R	Right Angle Smart FINN®, pictured above
TC08SF-V	TC03SF-V	Vertical Smart FINN® pictured above
TC08SF-C	TC03SF-C	3-Pin Header Connector Smart FINN® (no probes)
TC08SF-L	TC03SF-L	L-shaped Smart FINN®

8. Sources of Error

8.1 Wiring

Special care should be paid to the wiring instructions in section 9.1. Improper wiring will result in over-heating and damage to the part. If miss-wiring has occurred, immediate replacement of the damaged part is recommended.

8.2 Outside light and adjacent LED's

Light from sources other than the device being tested should be prevented from reaching the sensor surface while making measurements. The ambient light from factory lighting could make a green led that normally reads 8.68kHz read 8.9kHz.

8.3 Distance

The further away the sensor is from the LED, the lower the voltage response of the sensor. If the LED is dim (20mcd or less), the sensor face should be around 0.10" to 0.15" from the LED. LED's that are medium brightness (20-100mcd) can have a greater distance 0.15" to 0.25". And very bright LED's (100-200mcd) should be 0.25" or greater for best results. If using light pipes or light conduit this distance should be measured from the LED lens to the front face of the light pipe with a small gap between sensor and other end of conduit.

8.4 Vdd other than 5V

As Vdd is decreased to 3.5Vdc the frequency of the microprocessor will increase to about 2% above the 5V Vdd frequency. From 3.5V to 2.7V the frequency will start to return to the 5V value. Use 5V for Vdd when possible. When using 3.0v or 3.5v as the power source, the frequency limits can be adjusted based on the dark reading. For example the reading for dark is nominally 998.4Hz at 5V but you are using 3.3V as the power source and the dark reading is 1016Hz. This is a difference of 1.8% so all the expected frequency readings will be 1.8% higher. So instead of testing green for a frequency of 8.68 kHz +/- 3% at 5V, the test would look for 8.84 kHz +/-3%.

8.5 Saturation

If the output frequency is 2.02 kHz the sensor is in saturation. Reduce the intensity of the LED if possible. Another way to get out of saturation is to move the sensor further from the LED or switch to a smaller diameter light conduit.

8.6 Temperature

As the temperature is increased, the frequency of the microprocessor decreases slightly. So if testing at 50 degrees Celsius the frequency readings may drop 1%. Likewise, if testing at 0 degrees Celsius the frequency would rise about 1%. Most test environments are kept between 20-35 degrees Celsius and the frequency variation due to temperature in this range is less than 0.3 percent.

9. Fixture Considerations

Drawings in section 15, 16, and 17 show the TC08SF-R (Right Angle Smart FINN) and the TC08SF-V (Vertical Smart FINN). There are 2 other part numbers available (TC08SF-C and TC08SF-L) which are the same as the TC08SF-V except the slotted probes are installed to the PCB. TC08SF-C leaves holes which will accept 25mil square posts for flexible fixture needs.

9.1 Wiring and Sockets

The sensor is mounted using three 100mil sockets. Industry standard 100mil sockets:

QA part number 100-SDN250W *For longer set heights QA 100-SDN251W may be useful.*

ECT part number SPR-25W-2

IDI part number R25W

Red Heatshrink (+) to Vdd (switched 5V typical)

Black Heatshrink (-) to Ground(0V ref)

Clear Heatshrink (o) Output to measurement device or switch matrix

When using the TC08SF, without probes and heat-shrink, please note that Power is marked with a + (plus) sign on the PCB and Ground is marked with a – (minus) sign on the PCB. ***Improper wiring will result in over-heating and damage to the part.***

9.2 Distances

One major advantage of the Smart Finn® is that it does not need to be touching the LED. As a matter of fact it should be at least 0.1 inches from the LED. Distances are not critical unless the LED is very dim or very bright.

9.3 Light pipe and light conduit

If devices are too close together and light conduit is needed there are several options available. First, you can use jacketed or unjacketed. We recommend unjacketed because it has a greater core diameter. Some people prefer jacketed because it has a visible barrier to outside light but the outer shell of the unjacketed reflects outside light as well. In typical applications, the distance is short (less than 12”) and conduit is somewhat protected by fixture hardware so jacketed is not needed.

Core diameter must also be selected. For the Smart Finn® the sensor surface is a square with 1.15mm sides. 2mm diameter unjacketed conduit will cover the complete surface of the sensor. Now consider the other end. The LED which may vary slightly in placement, must remain in front of the transmitting portion of the conduit. For small surface mount LED’s 2mm is sufficient to make consistent measurements. For other physical situations 2.5 or 3mm maybe needed.

Cutting and polishing is not difficult. Remember we are not making a critical fiber optic coupling, we merely want to get the light in the conduit. After cutting the conduit, smooth the surface using fine sandpaper. You must remove any melted or opaque material created during the cutting. Once the face appears smooth use cardboard (unpainted) for a final polishing. If you would like to check your finish, view an LED through the conduit and verify the brightness is not diminished. If the end is not polished enough, then some light will reflect off the jagged surface rather than enter the conduit and brightness will be reduced.

10. Absolute Maximum Ratings

Over operating free-air temperature range (unless otherwise noted)†

Supply voltage, VDD (see Note 1).....	6 V
Operating free-air temperature range, TA.....	0C to 70C
Storage temperature range.....	-25C to 85C
Maximum current or output.....	±25 mA

† Stresses beyond those listed under “absolute maximum ratings” may cause permanent damage to the device. These are stress ratings only, and functional operation of the device at these or any other conditions beyond those indicated under “recommended operating conditions” is not implied. Exposure to absolute-maximum-rated conditions for extended periods may affect device reliability.

NOTE 1: All voltage values are with respect to GND lead.

11. Recommended Operating Conditions

	Min	Nom	Max	Unit
Supply voltage, VDD	2.7	5	5.5	V
Operating free-air temperature range, TA	0	25	70	Celcius
Supply current	-	7.5	12(Note1)	mA

Note1: Additional loads on output pin not included

12. 5-V DC Electrical Characteristics

Characteristics(1)	Symbol	Min	Max	Unit
Output high voltage	VOH			V
I _{Load} = -2.0 mA, all I/O pins		VDD-0.4	VDD	
I _{Load} = -15.0 mA, all I/O pins		VDD-0.8	-	
Output low voltage	VOL			V
I _{Load} = 1.6 mA, all I/O pins		V _{SS}	0.4	
I _{Load} = 15.0 mA, all I/O pins		-	0.8	

1. VDD = 4.5 to 5.5 Vdc, VSS = 0 Vdc,

13. 3-V DC Electrical Characteristics

Characteristics(1)	Symbol	Min	Max	Unit
Output high voltage	VOH			V
I _{Load} = -0.6 mA, all I/O pins		VDD-0.3	-	
I _{Load} = -4.0 mA, all I/O pins		VDD-1.0	-	
Output low voltage	VOL			V
I _{Load} = 0.5 mA, all I/O pins		-	0.3	
I _{Load} = 6.0 mA, all I/O pins		-	1.0	

1. VDD = 2.7 to 3.3 Vdc, VSS = 0 Vdc

14. Other Application Notes

14.1 Low Pass Filter for DC Measurements

Some meters will not average for DC voltage measurement. If your meter does not average you can add a simple low pass filter (R=10k, C=0.1uf) to the output for DC measurements. You must wait at least 5msec after the sensor has acquired a reading to get a stable voltage on the capacitor of the low pass filter.

Also, frequency measurements should still be made at the output of the sensor.

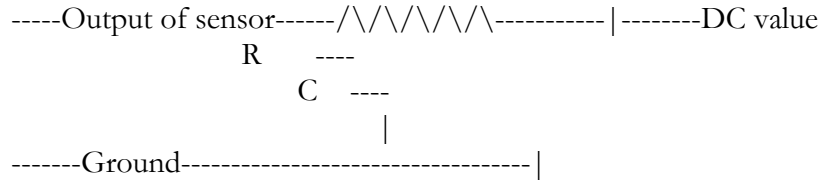

See website for further test examples and application notes.

14.2 Passive Measurements for Wiring Verification

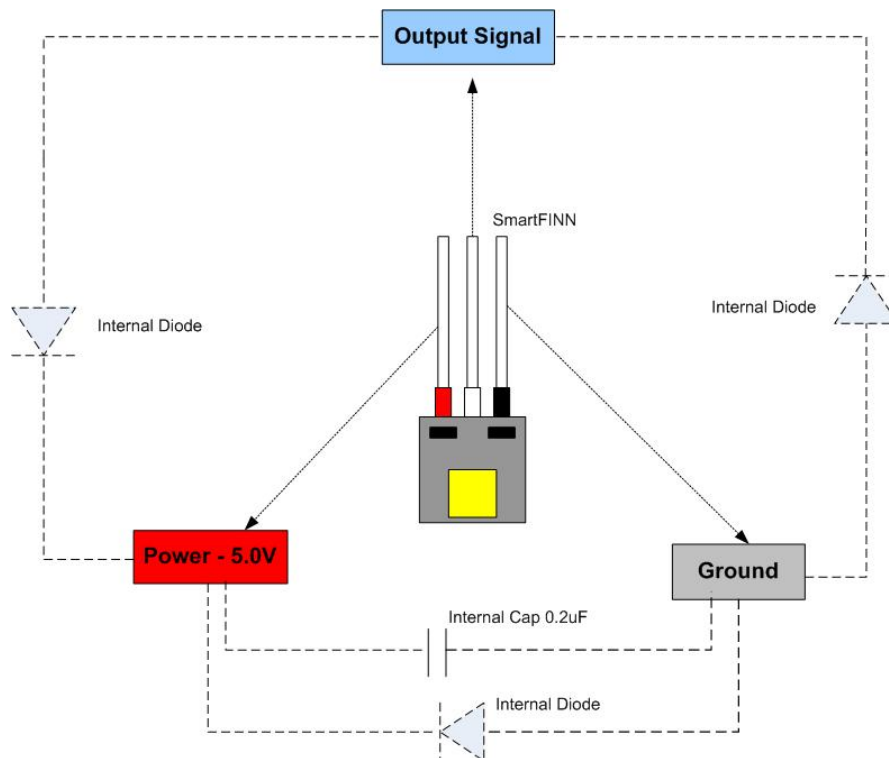

15. Drawing – TC08SF-R, Smart FINN® Right Angle

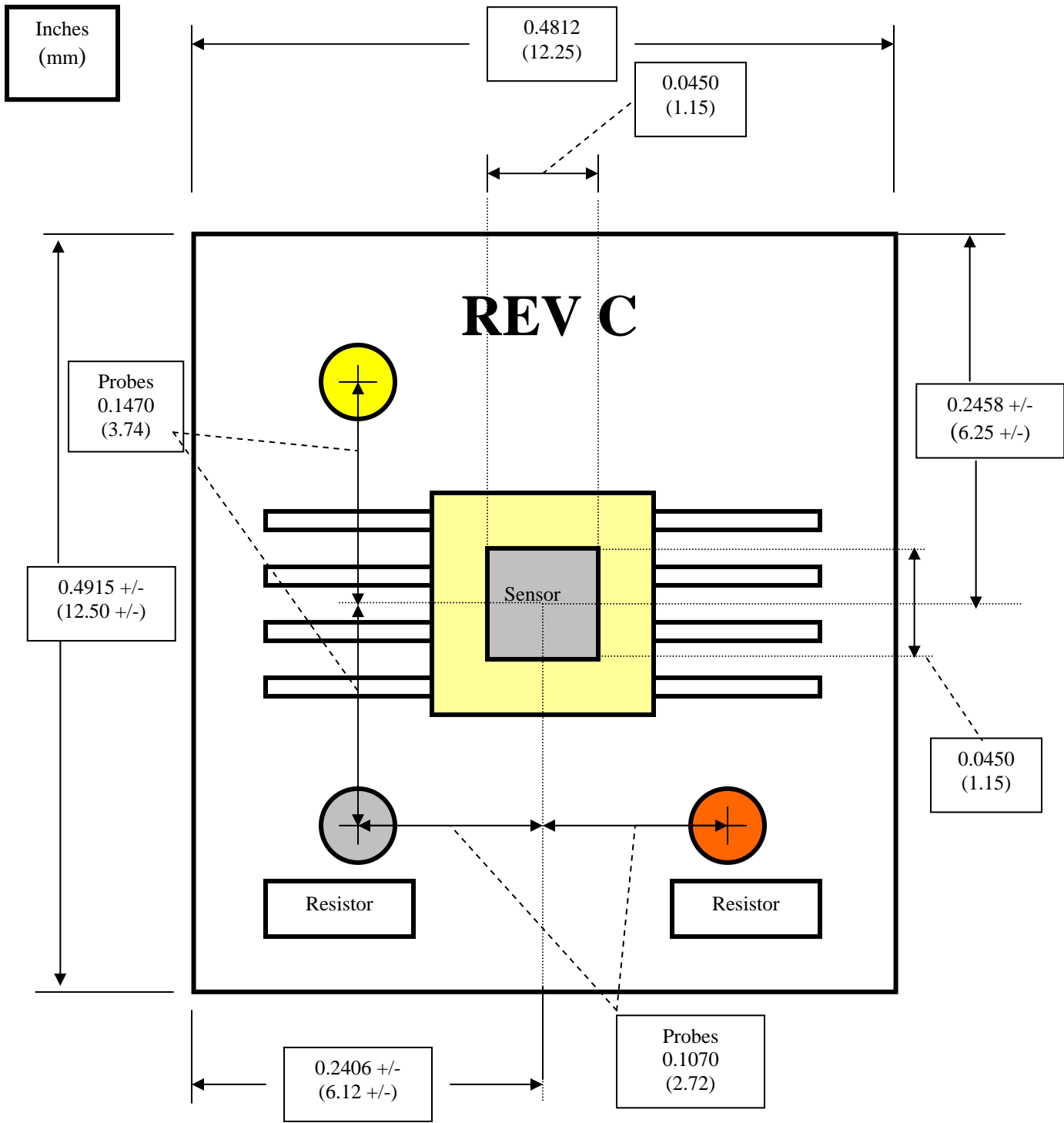

TC08SF-R
Top/Sensor View

16. Set Height for Right Angle Smart FINN®

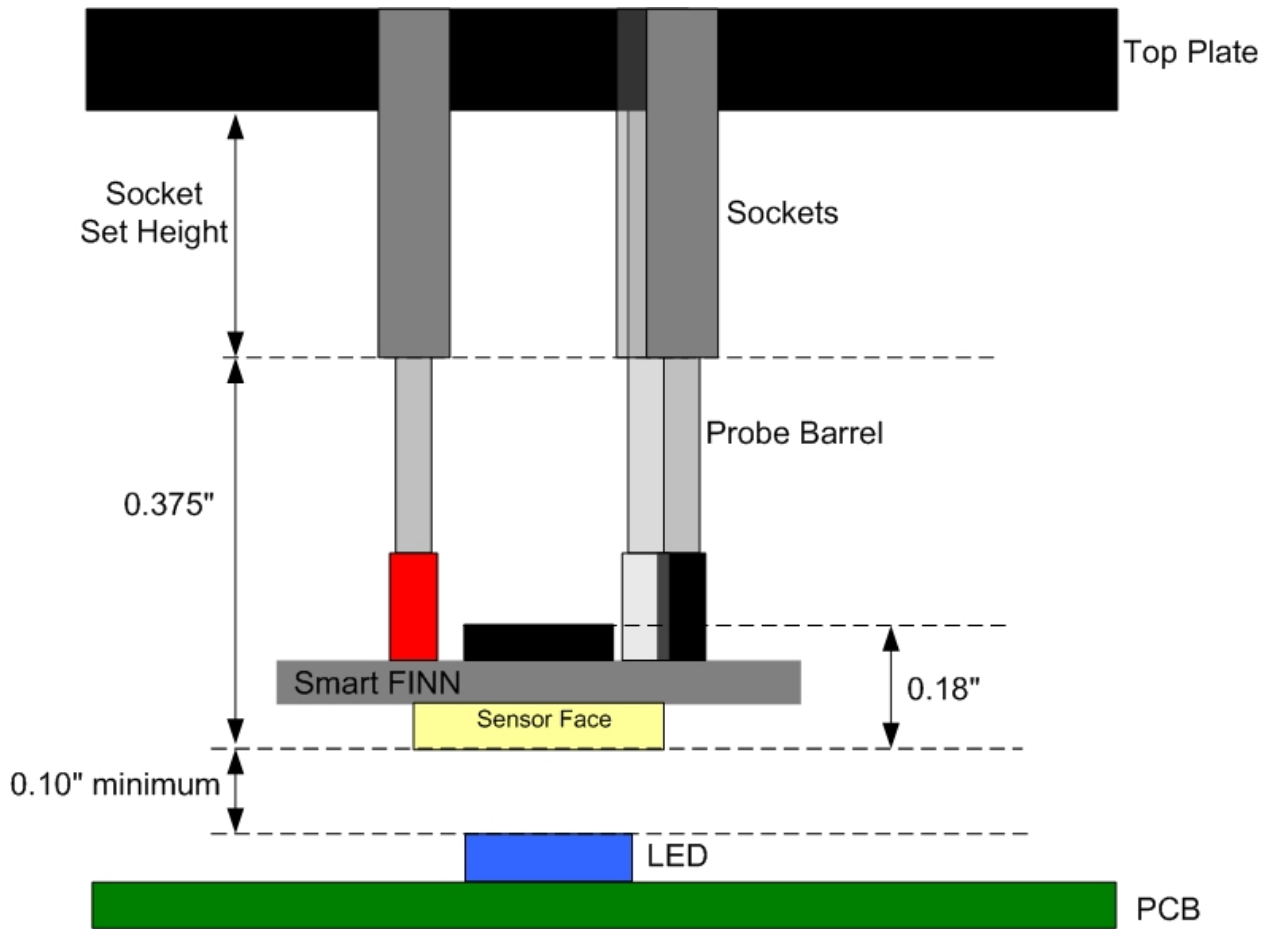

Note: Drawing not to scale.

17. Drawing – TC08SF-V, Smart FINN® Vertical

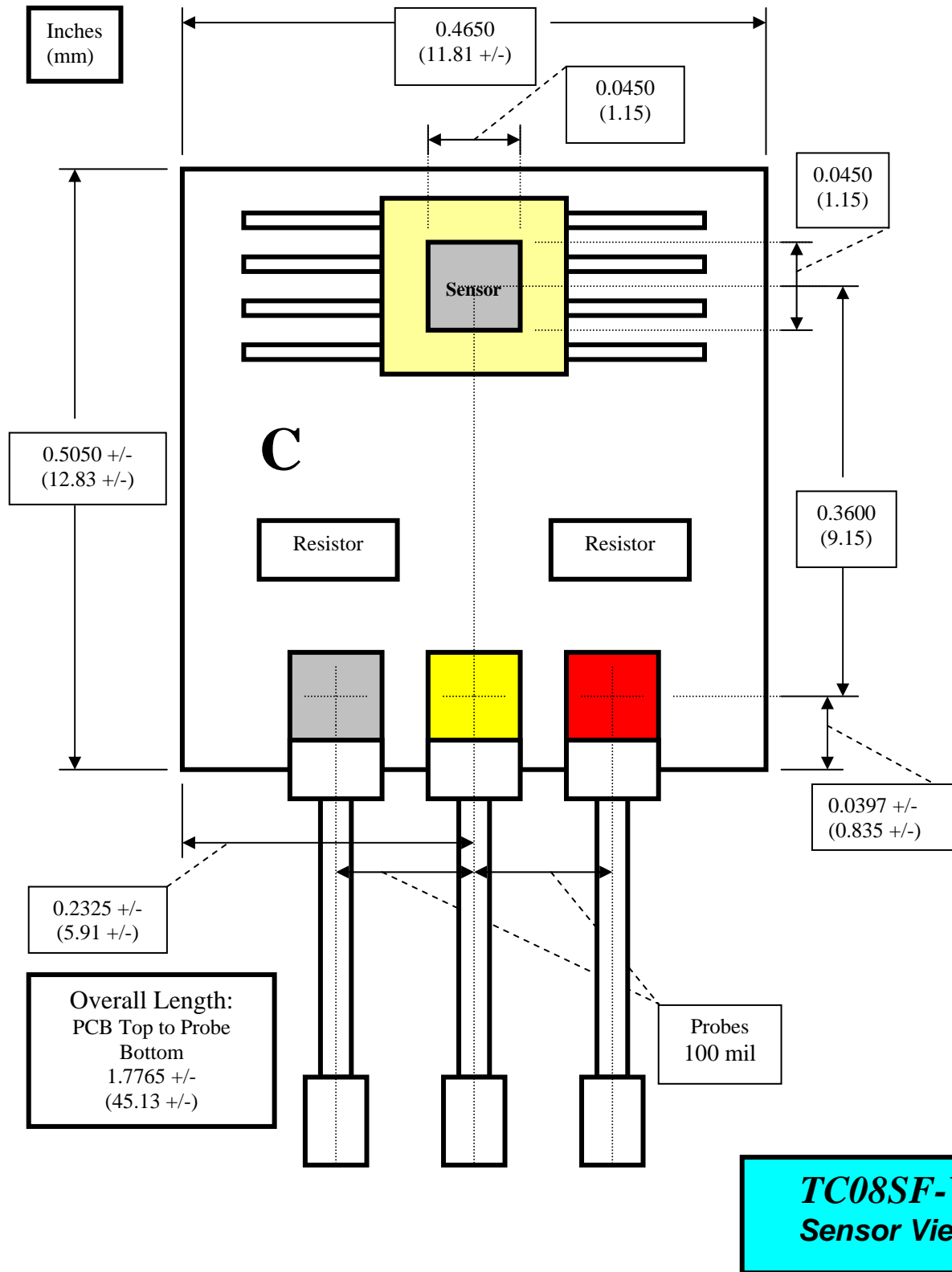

18. Revision 2.5 – January 1, 2008

The manufacturer of the sensor used on the Smart FINN product has made a slight change to their sensor. The original part is now obsolete and has been replaced with a new part. As of January 1, 2008, the Smart FINN will have the new sensor. Although in most cases, this change will be functionally transparent, some users may notice a very slight change in readings (noted on the measurement chart with double red asterisks - **)

Minor firmware changes were made to compensate for the manufacturer part change of the sensor. The difference is most notable on blue or blue-green LEDs.

The new replacement parts are mechanically equivalent to the now obsolete part.

The new part numbers are:

TC08SF-R	Smart FINN [®] Right Angle
TC08SF-V	Smart FINN [®] Vertical
TC08SF-C	3-Pin Header Connector Smart [®] FINN (no probes)
TC08SF-L	L-shaped Smart [®] FINN

- PCB Marking Change

The new Smart FINN can be easily identified visually by a resistor component marking change from 103 to 123.

19. Revision 2.42 – August 1, 2006

- PCB Marking Change

As of August 1, 2006, a lead-free version of Smart FINN[®] became available.

The lead-free PCB of the Right Angle Smart FINN[®] (TC03SF-R) is marked with “REV C” at the top of the sensor.

The lead-free PCB of the Vertical Smart FINN[®] (TC03SF-V) is marked with a letter “C” at the bottom left of the sensor.

The code remained at revision 2.42.

20. Revision 2.42 – March 17, 2005

As of March 17, 2005 the following enhancements were completed on the Smart FINN®.

- Improved Accuracy - New Output Frequency Readings

The sampling algorithm was enhanced, improving the accuracy of the sensor readings and the output frequency. As a result, some minor changes to the output frequency may be noticed from the previous revision. The new output frequency readings for revision 2.42 are listed in The Table of Typical Readings.

- PCB Marking Change

The 2.42 revision code may be physically identified by a marking on the black PCB of the Smart FINN®.

The PCB of the Right Angle Smart FINN® (TC03SF-R) is marked with “REV B” at the top of the sensor.

The PCB of the Vertical Smart FINN® (TC03SF-V) is marked with a letter “B” at the bottom left of the sensor.

21. Change to Smart FINN manual - June 2009

Corrected an error in section 6.1 regarding the output voltage. Also, added reference to Smart FINN Tool.

Changed example in section 6.2 regarding the frequency output to match typical values provided in “Typical Measurements” table in Section 5.5.

22. APPENDIX A

Typical Measurements for Revision 2.3

TYPICAL MEASUREMENTS @Vdd=5.0				
Color	nm	mcd	kHz	Vdc
Red	635	150	12.0	4.5
Amber	608	10	10.6	3.0
Yellow	585	150	9.38	4.3
Green	565	150	8.68	4.0
Blue	430	x	6.90	x
OTHER MEASUREMENTS@Vdd=5.0				
Infrared	Up to 660	x	12.1-12.5	x
Ultraviolet	Down to 380	x	6.25-6.8	x
Fluorescent	multiple	x	4.0	x
White(red dominant)	multiple	x	4.4-6.0	x
White(blue dominant)	multiple	x	3.2-4.0	x
Saturation	n/a	Above 200*	1.996	4.8
Dark	n/a	Below 1*	0.998	0.2